

# Guides - Fitting a Nova GSi Tailgate Spoiler

DISCLAIMER: The information in these documents are a collection from experience (friends or myself), magazine articles, mailing lists and Internet web sites etc. So don't take these as 100% correct gospel, hence I don't take any responsibility for any of these guides.



Difficulty Rating: 3/5 - Feeding the wire is the worst part.



Download printable [Adobe Acrobat file](#) (405K)

Created: 28 Jan 2001



Download zipped [web page version](#) (1.7MB)

Revision 1

Click on any of the pictures for a larger view.



Before...



...and after.

This is a step-by-step guide on fitting the rear Nova GSi tailgate spoiler to any model of Nova. However, this guide was carried out on a Nova GTE, which already had a spoiler fitted, hence the four bolt holes were already in place, making the job a lot easier. For Nova models without a spoiler when made, will have to make four additional holes in their tailgate. How this is done is up to you, but if the holes are drilled in the wrong place, it makes fitting the spoiler difficult as the location is critical.

Also removing the old SR/GTE style spoiler is quite tough, in that you don't want to damage the paintwork underneath. This Nova was going into a paint shop anyway, hence the lack of looking careful on the tailgate paintwork. A good method would be to warm up the spoiler first (or leave it out in a hot day) and use a paint scrapper to get underneath. A lot of pulling is required.

This particular kit came with an additional water jet nozzle. The original nozzle on the tailgate can be remove. But when replacing, keep a tight grip on the water tube, as Vauxhall seems to have given no slack what so ever on the tube. Hence it can be easily be lost in the tailgate.

The next difficult task is the wiring, or rather feeding it around parts of the car. A long 'pick-up grabber' was obtained, which makes life a lot easier and also a long flexible cable tie seems to be only answer at times. The actual wiring is easy, circuit diagrams are provided in the guide. Remember to test the circuit as you progress, the last thing you want is a fault when you've put everything in place, only to take it all apart again.

## PARTS



Nova GSi spoiler with brake light

Paint scrapper

Long plastic cable ties

Pick-up grabber tool

Extra wire (speaker type)

Bullet plugs (various)

Cross head screw driver

Flat blade screw driver

Pliers

Bullet plug crimper tool

9v battery

White sprit

Wire cutters

Sticky tape

Water sealant

Haynes Book

Electric Dill

Drill bits

Rust stopper

T-Cut (bottle)

## COST

Nova GSi spoiler with brake light

£120

- The spoiler came from [Superspeed](#) in Scotland. Price includes P&P and 5% [PNG](#) discount.

1 litre of white sprit

70p

Pick-up grabber tool	£2.50
Long plastic cable ties (pack)	£1.50
9v Battery PP3	£3.50

- The Pick-up Grabber Toll came from [Maplins](#), order code BN98G.

▣ Fitting the Spoiler: ▣

**General Notes:**

Just before you start, make sure you note the following:

- If you don't have one, buy a Haynes manual for your car and have this in front of you. You'll may need this on how to remove the spoiler and trim etc.
- Before fitting the spoiler to the car, test the brake light out first. The brake light on this unit was an LED array which works on 12v. Any lower and the intensity of the light produced is reduced. You can not damage the LED's by reversing the power (unless it's a higher voltage), just swap the connections around. Generally Red is positive and Black is negative (earth).
- The spoiler kit came supplied with bolts, but these are not long enough to protrude out the other end of the tailgate. Hence longer self tapping screws were obtained. These simply dug into the spoiler when fitted to the car.
- Removing the water jet nozzle can be tricky. A flat blade screw driver is required to push back the plastic lugs underneath. A pair of pliers may also help. Remember NOT to lose grip of the water pipe in the tailgate, as there is virtually no slack given.
- When the old spoiler is removed (if you have one), the paint work can be restored a bit by using T-Cut, as it's bound to be dirty and dull when the spoiler was on top of it.
- An extra pair of hands may be required when fitting the spoiler on, as it is difficult to keep the spoiler in position and screw it down at the same time.

OK, got all the above? Then follow the steps below (remember to click on the pics for a bigger view):

**Step 1**



Remove the packaging and check the contents. It should come with ample wire (2 core), screws, protective pads and tape, plus a different type of water jet nozzle.

**Step 2**

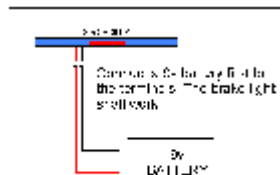

Test the brake light first by connecting the supplied wire with connectors onto the brake light. Connect a 9v battery (as shown). If it doesn't work, either the battery is dead, faulty brake light or swap the connections.

**Step 3**



Begin to remove the original spoiler on the tailgate. The spoiler is held down with double sided tape. You'll have to pull hard to remove it. Use a paint scrapper, rapped in cloth, to get underneath (don't scratch the paintwork).

**Step 4**



**Step 5**



**Step 6**



With the spoiler removed, the

Once the spoiler is removed from the tape, only 4 nuts are holding it onto the car. Remove these with a 8mm socket. Some models may have flat U shaped spring clips.

Withdraw the spoiler from the tailgate. The spoiler will have 4 long screw threads sticking out of it. Clear up the surface of the tailgate and remove any excess tape and dirt.

water jet nozzle is exposed. Remove the nozzle (with a small flat blade screw driver), take hold of the water pipe and replace with the new nozzle supplied in the kit.

### Step 7



The bolts supplied in the kit are not long enough and the heads are too wide to fit through the original 4 holes. Obtain longer self tapping screws.

### Step 8



The screws should go straight through the tailgate and protrude approximately 1 inch from the other end (as shown). Use washers if the heads are too small.

### Step 9



Trial fit the spoiler at this stage, perfecting the fit. Exercise the tailgate up and down to see if it catches anywhere. Note: the spoiler may interfere with a bee-sting aerial if fitted.

## Electrical Wiring:

### General Notes:

Just before you start, make sure you note the following:

- If you don't have one, buy a Haynes manual for your car and have this in front of you. You'll may need this on how to remove the spoiler and trim etc.
- Fit the supplied wire in the order shown, because it has to be fed through several items in a particular order. Failure to do this will almost result in removing all the wire again and re-feeding it (= hassle, these are the words from experience ;-).
- Feeding the wire through the car can be very stressful. This may take most of the time up, because you can sometimes never 'quite' get the wire through the holes in the tailgate etc. The combination use of the long plastic cable ties and the Pick-Up Grabber tool came in VERY useful.

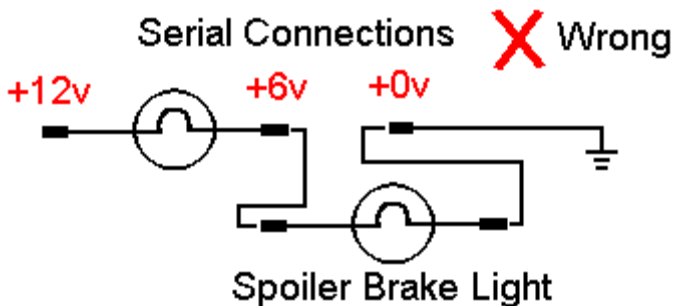

There are two ways to wire up the brake light on the spoiler. Either way will work, but one method will work better than the other. The two choices are 'serial connection' (bad) and 'parallel connection' (good). The two diagrams on the left show the two possibilities.

The serial connection is bad because it takes 50% (6v) of the voltage drop away from the original stop lamp. This makes it appear to be half bright when viewed from the rear. Because the other 50% (6v) of the voltage is now across the new brake spoiler lamp.

The best way is to connect the brake light up in parallel in the circuit. This way both lamps get 12v across them. Hence the intensity of the light emitted

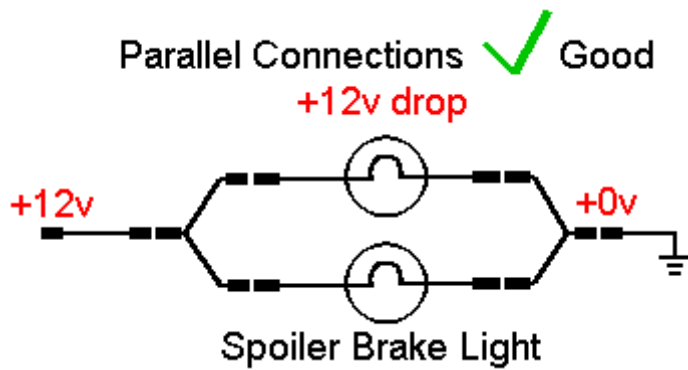

is not affected. See the Y adapters in use here.

- The wire and colour coding in this guide were for a Nova GTE 1989. Vauxhall may have changed the colouring code on some models and year, check first in the Haynes manual before proceeding. Otherwise you could cut the wrong wire (again words here from experience).
- Some of the pictures taken of the wiring to the multi-connector show several bullet plug connections. This is because the [Euro Light conversion](#) was previously carried out on this car. Hence the mass of wires.

OK, got all the above? Then follow the steps below (remember to click on the pics for a bigger view):

### Step 10



Lay the spoiler upside down on top of the roof. Feed the wire supplied through the GSi spoiler first (as shown). Drill an extra hole in the tailgate for the brake light wire.

### Step 11

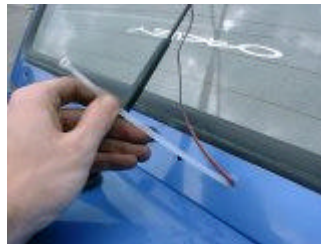

Fiddly bit, feed the extra wire down into the tailgate. Use a long cable tie and tape the end of the wire onto to this. Feed the cable tie down towards the grommet tube.

### Step 12



With the use of a pick-up grabber, grab hold of the end of the cable tie. Pull this all the way through so there is enough length of wire to feed down the C pillar and into the boot space.

### Step 13



Feed the rest of the wire all the way through the S bend grommet tube. Keep enough slack in the tailgate itself so that the spoiler can be removed easily in the future.

### Step 14

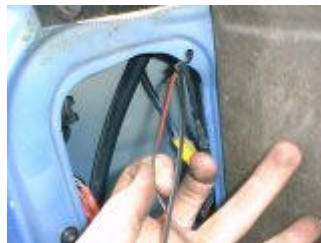

Refit the S bend grommet back and feed the last part of the wire down the C pillar. Open the flap in the boot to pull the wire through (use the pick-up grabber if necessary).

### Step 15



With enough wire inserted into the tailgate and car, fit the brake light onto the GSi spoiler and screw on the cover. Don't fit the spoiler to the car just yet, keep it where it is.

### Step 16

### Step 17

### Step 18

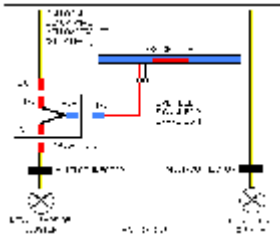

Look at the circuit diagram above. This is the connection of the live feed signal to the brake light. The brake light has to be connected in parallel to the rear stop light. The use of a Y adapter is required.

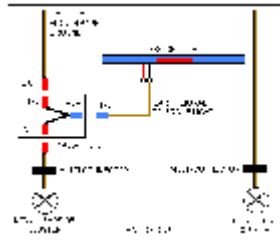

Look at the circuit diagram above. This is the connection of the earth feed to the brake light. The brake light has to be connected in parallel to the rear stop light. The use of a Y adapter is required.



The Y adapter is simply two pieces of wire connected together by a single bullet plug (female). Each end is terminated by another bullet plug (male & female). This splits the signal up to the brake light on the spoiler.

### Step 19



At the rear of the nearside back cluster, remove the black multi-connector. With the use of the circuit diagrams, locate the two required colour wires.

### Step 20



Find the live brake signal first (black wire with yellow tracer). Cut the wire and fit bullet plugs to either end and then connect the Y adapter on.

### Step 21



Find the earth wire next (thick brown wire). Cut the wire and fit bullet plugs to either end. Connect the Y adapter to the bullet plugs and then fit the spoiler brake light wire to the Y adapters.

### Step 22

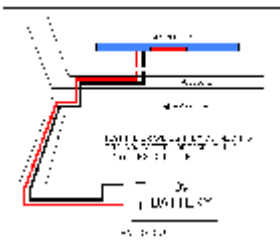

To test if the wiring is correct, do the same test as before and connect a 9v battery to the spoiler wire. Disconnect it from the Y adapters and connect as shown.

### Step 23



Once the wiring is correct, connect the multi-connector back and fit the spoiler to the tailgate. Small round pads are provided for each hole (to protect paintwork and make water tight).

### Step 24



Once fitted, with the aid of a friend, try the brake light out and see if it works. You may want to place sealant between the spoiler and the tailgate to prevent water from seeping in-between.

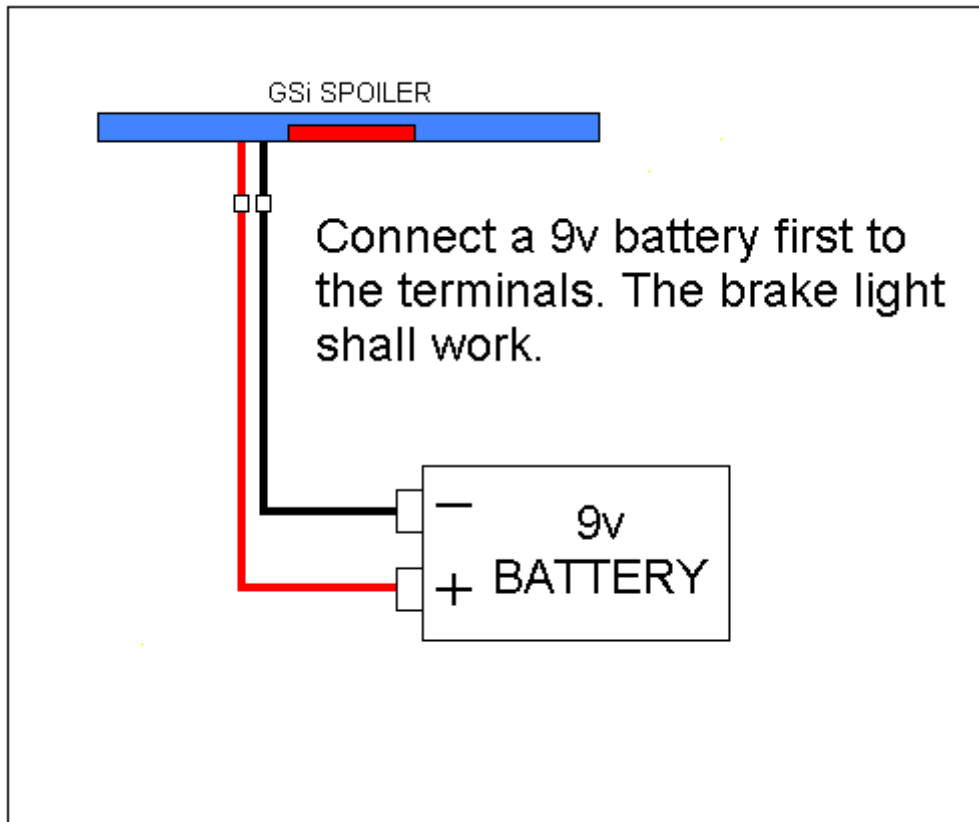

Step 2

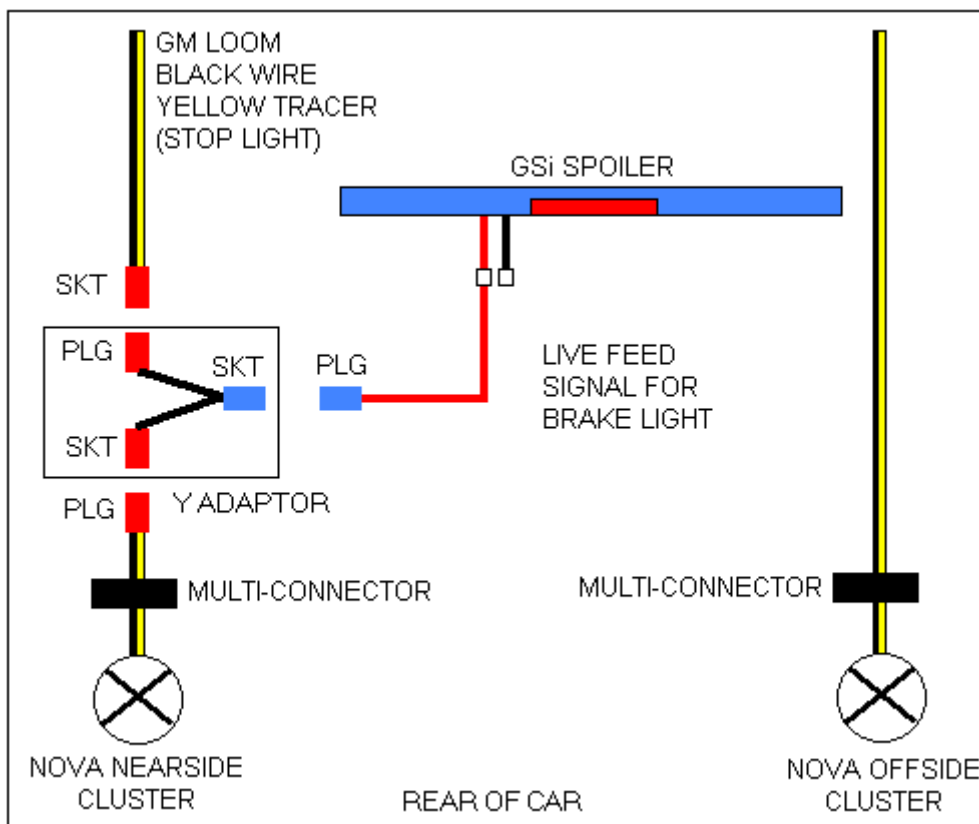

Step 16

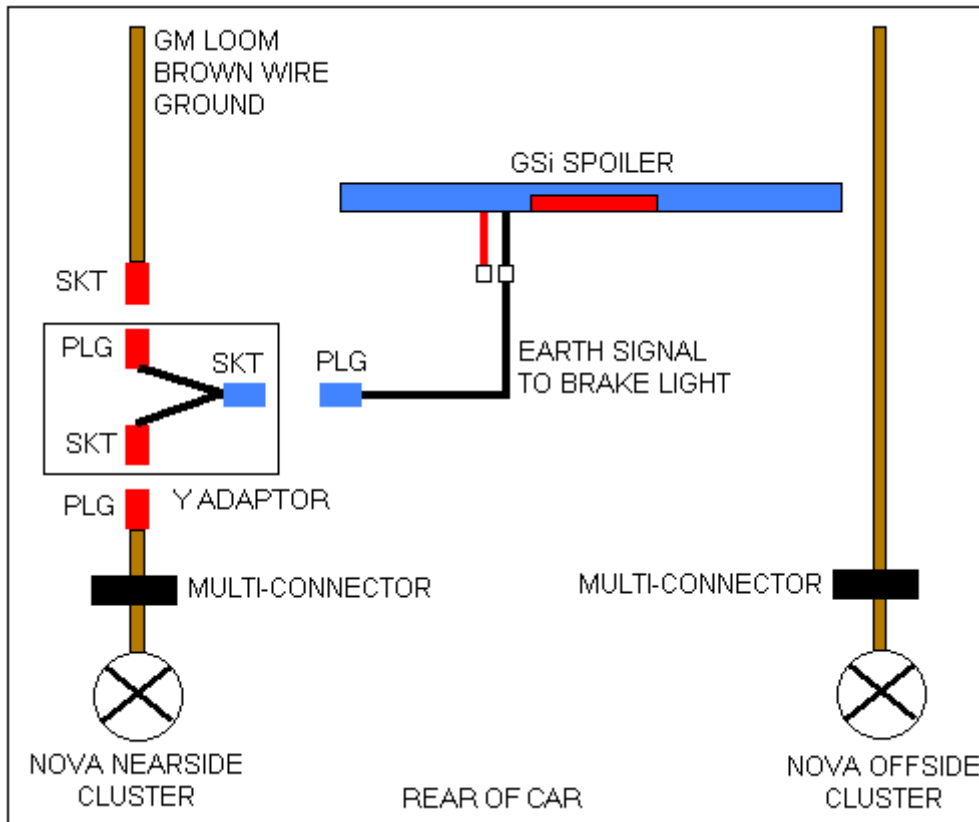

Step 17

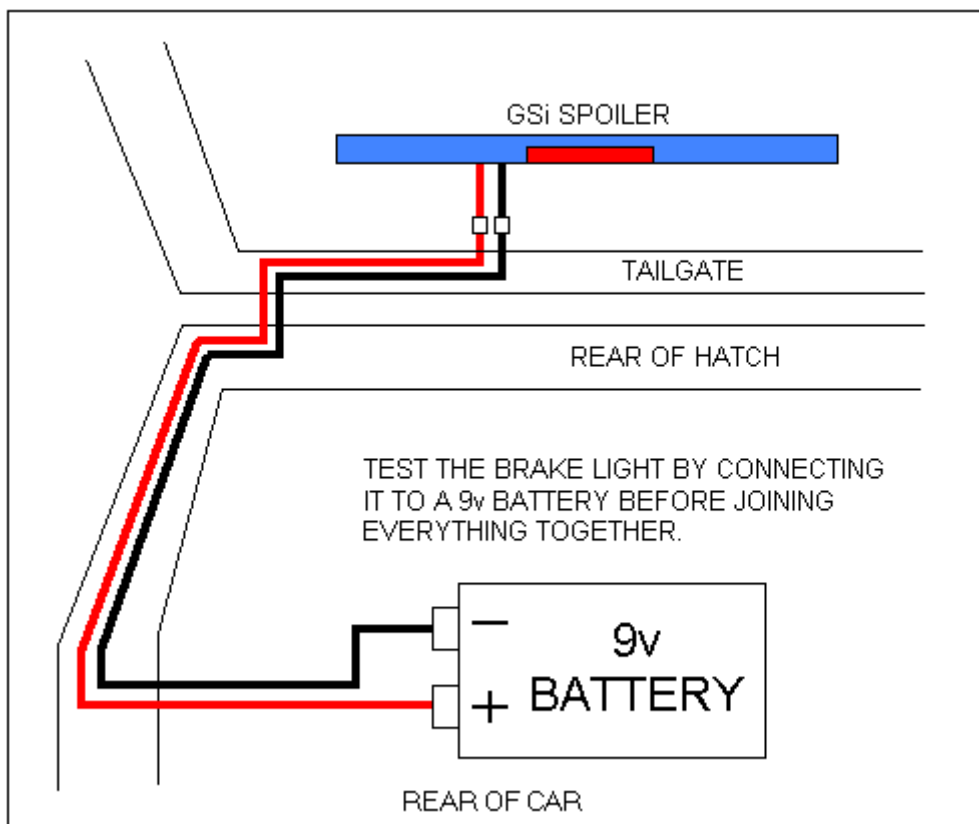

Step 22

