

# Guides - Fitting a Universal Evo Spoiler

DISCLAIMER: The information in these documents are a collection from experience (friends or myself), magazine articles, mailing lists and Internet web sites etc. So don't take these as 100% correct gospel, hence I don't take any responsibility for any of these guides.



Difficulty Rating: 3/5 - More time spent = better quality.



Download printable [Adobe Acrobat file](#) (405K)

Created: 23 Feb 2001



Download zipped [web page version](#) (1.7MB)

Revision 1

Click on any of the pictures for a larger view.



Before...



...and after.

This is a step-by-step guide on fitting a universal Evo spoiler onto a Calibra. The method applied here can also be transferred onto other models, for example the Cavalier. The guide shows a aftermarket spoiler removed and replaced with the Evo spoiler, hence some holes in the tailgate were already in place. Some owners have factory fitted spoilers, and if they have a centre mounted screw down point (i.e. Calibra Turbo deep flat spoilers), then this hole has to be welded over and resprayed, bumping up the cost. Because the Evo spoiler is light, only 2 bolts on each leg are required, and bonding it down to the tailgate should be more than enough.

This particular spoiler has an integrated brake light, the guide also shows you how to wire this up to your car electric's too. The most time consuming part of this modification is the preparation. The spoiler will almost definitely not fit the tailgate properly when you first sit it on the tailgate. It will wobble end to end somewhere. The feet need sanding down until it is stable. This is the time consuming part, sanding, checking, sanding, checking....you get the idea.

Then once it sits straight, the surface of the Evo spoiler itself needs attention. There will be many small cracks and holes in the fibreglass. If your having a body shop spraying the item, you don't need to worry about this. But again, patience prevails and you will get an ultra smooth finish on the surface, making spraying easier.

## PARTS



Wire cutters  
Electric Dill  
Hammer  
Small tubing

Universal Evo Spoiler	Thin cardboard	Long plastic cable ties
Pick-up grabber tool	Extra wire (speaker type)	Bullet plugs (various)
Cross head screw driver	Flat blade screw driver	Pliers
Bullet plug crimper tool	9v battery	White sprit
Sticky tape	Sanding (grit) paper	Haynes Book
Drill bits	Rust stopper	T-Cut (bottle)
Centre punch	Pencil/graphite	Thick self tappers
Silk-o-flex bond	Sanding block	Primmer paint

## COST

MC Rallying Evo spoiler with brake light	£160
1 litre of white sprit	70p
Pick-up grabber tool	£2.50
Long plastic cable ties (pack)	£1.50

- The spoiler came from [www.ccmotorsport.co.uk](http://www.ccmotorsport.co.uk). Price includes P&P and VAT.
- The Pick-up Grabber Toll came from [Maplins](http://Maplins), order code BN98G.
- Sanding paper can be purchased from

9v Battery PP3	£3.50	your local car accessory shop (usually sold as a kit). ● The Quick Foam Filler are used for wall cavities, this can be purchased from B&Q and other DIY shops.
Bottle of Rust Stopper	£3+	
Sanding down paper (200 to 800 grit)	£5	
Quick foam filler (bottle)	£5+	

## ▣ Fitting the Spoiler: ▣

### General Notes:

Just before you start, make sure you note the following:

- If you don't have one, buy a Haynes manual for your car and have this in front of you. You'll may need this on how to remove the spoiler and trim etc.
- Before fitting the spoiler to the car, test the brake light out first. The brake light on this unit was an LED array which works on 12v. Any lower and the intensity of the light produced is reduced, but still works. You can't damage the LED's by reversing the power (unless it's a higher voltage), just swap the connections around. Generally Red is positive and Black is negative (earth).
- The spoiler kit came supplied with bolts, but I found these would not fit the thread hole that was in the spoiler. So I replaced these with thick self tapping screws, about 3 on each foot. These simply dug into the spoiler when fitted to the car.
- When you first fit the spoiler temporarily on the tailgate for the first time, it will most likely wobble or rock. The process of sanding down, checking, sanding down again etc. takes about 60% of fitting these universal spoilers. Take your time on this to get a nice snug fit.
- This particular spoiler is hollow, which keeps it light. The thickness of fibreglass for the feet, and where you screw into is VERY thin, only about 2-3mm in thickness. When sanding down the feet to get it level, I sanded through the thickness and produced a hole (as shown in the guide). You have to fill up the void so that you have something to screw into and bond onto as well.
- When the Evo spoiler is screwed down on the tailgate, and it is closed, take a note of the gap between the over hang of the feet and the top surface of the rear quarter. The overhang may bang on the rear quarter when the tailgate closes, so sand this down until there is a comfortable air gap between the two. If you don't you may mark the rear quarter, which will either crack the spoiler or damage the paint surface (= respray).
- When the old spoiler is removed (if you have one), the paint work can be restored a bit by using T-Cut, as it's bound to be dirty and dull when the spoiler was on top of it. If it's too heavily pitted or even scratched, then you may have no choice but to get the tailgate resprayed.
- An extra pair of hands may be required when fitting the spoiler on, as it is difficult to keep the spoiler in position and screw it down at the same time.

OK, got all the above? Then follow the steps below (remember to click on the pics for a bigger view):

### Step 1



Remove the packaging and check the contents. Should have enough wire and some bolts in the kit. I used wide self tapers in the end.

### Step 2



Test the brake light first by connecting it to a 9v battery, all the LED's shall light up.

### Step 3



Begin to remove the original spoiler (if fitted) and sit the new spoiler on the tailgate.

**Step 4**

Draw around the spoiler feet to what seems best fit, as it will probably be wonky.

**Step 5**

Roughly draw where you want the holes to be and the position of the spoiler.

**Step 6**

With the spoiler removed, make the bottom of the feet flat. Grind the worst down first.

**Step 7**

Then use sand paper. This spoiler is hollow, and it now needs filling up, otherwise the screws have nothing to grip.

**Step 8**

First pull enough wire out from the spoiler for some slack before it gets filled up. About a foot shall do.

**Step 9**

Fill a large amount of space up with old newspaper or magazines.

**Step 10**

Then squirt fast expanding foam, remember to drill some air escape holes in the feet.

**Step 11**

Wait 24 hours for it to go fully hard.

**Step 12**

Once set, sand down the foam to a flat finish, there may be still some small holes left.

**Step 13**

Fill these in with fibreglass filler and sand down.

**Step 14**

Again keep checking to see if the feet are flat and it doesn't wobble.

**Step 15**

Sit the spoiler back on the car and draw around the feet with a pencil on a thin piece of card.

**Step 16****Step 17****Step 18**



The spoiler already may have holes drilled, mark these out on the card as a template.



Draw around the template to locate the holes and begin to drill them. Remember a hole for the brake wire. Use rust stopper afterwards on fresh cuts.



Then temporarily screw on the spoiler and close the tailgate.

### Step 19



Make sure there is enough gap between the lip of the foot and the rear quarter. Sand down as necessary.

### Step 20



Keep on trial fitting and sanding down until the spoiler looks right and doesn't rock.

▀ Rubbing down: ▾

### General Notes:

Just before you start, make sure you note the following:

- This is not a definitive guide on how to rub down fibreglass and paint it, it is just a guide to point out a few hints on how to get a nice finish.
- There are several grades of sanding down paper (wet and dry) available, they are ranked as 100 = rough, and 1000 = smooth (almost feels like paper). Use 200 grit to begin with, followed by 400 grit. To get a smooth finish use 600 grit. 800 to 1000 is rarely used as it takes ages before you see any noticeable difference. This grit paper can be purchased from B&Q or your local car accessory shop.
- When sanding down, use a small amount of water to clean away the rubbings and to clean the grit paper free from fibreglass/paint. This also assists in making a smoother finish too.
- Use primer to 'see' imperfections in the surface, then fill it up with fibreglass filler (for large areas) or filler (for small holes/cracks).
- Everytime an area is sanded down, it should ideally be re-primed again to see the effect done. This will be a long winded process of sanding, checking, sanding, checking etc.
- The brake light should be removed from the spoiler and taped up with news paper. As you don't want primer over spray on it.
- When spraying, use light layers, never think ones. About 5 light layers will give a nice even coating. If your too close, runs will appear and you have to rub it down again. If your doing this outside, there must be no wind in the air (otherwise it's difficult to control the flow spray).

### Step 21

### Step 22

### Step 23



With the spoiler flat and steady on the car, remove and spray the surface with primer.



The primer shows up imperfections in the spoiler, use filler or fibreglass to fill them up



Then rub down the filler and fill again, then spray. Repeat until surface is smooth.

Electrical Wiring:

**General Notes:**

Just before you start, make sure you note the following:

- If you don't have one, buy a Haynes manual for your car and have this in front of you. You'll may need this on how to read the wiring diagrams and colour codes of wires for your particular year of car.
- Fit the supplied wire in the order shown, because it has to be fed through several items in a particular order. Failure to do this will almost result in removing all the wire again and re-feeding it (= hassle, these are the words from experience ;-).
- Feeding the wire through the car can be very stressful. This make take most of the time up, because you can sometimes never 'quite' get the wire through the holes in the tailgate etc. The combination use of the long plastic cable ties and the Pick-Up Grabber tool came in VERY useful.

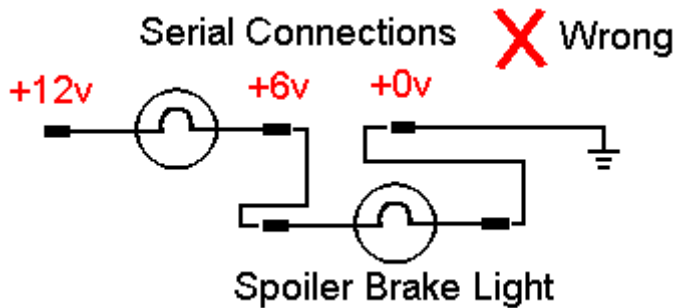

There are two ways to wire up the brake light on the spoiler. Either way will work, but one method will work better than the other. The two choices are 'serial connection' (bad) and 'parallel connection' (good). The two diagrams on the left show the two possibilities.

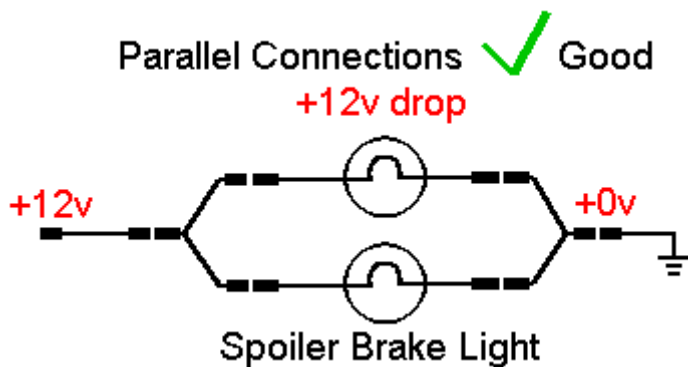

The serial connection is bad because it takes 50% (6v) of the volt drop away from the original stop lamp. This makes it appear to be half bright when viewed from the rear. Because the other 50% (6v) of the voltage is now across the new brake spoiler lamp.

The best way is to connect the brake light up in parallel in the circuit. This way both lamps get 12v across them. Hence the intensity of the light emitted is not affected. See the Y adapters in use here.

- The wire and colour coding in this guide were for a 'early type Calibra'. Vauxhall may have changed the colouring code on some models and year, check first in the Haynes manual before proceeding. Otherwise you could cut the wrong wire (again words here from experience).
- A lot of internal trim has to be removed to feed the brake wire in-between the panels (to make it neat). This is because the trim is layered in a 'house brick' fashion where one piece of trim covers a screw for another piece of trim etc.
- The use of 'Y Adapters' make the electrical installation much easier. These are simply two wires commonly joined together with one bullet plug. Follow the wiring diagrams as shown for

correct connections.

OK, got all the above? Then follow the steps below (remember to click on the pics for a bigger view):

**Step 24**



Remove the interior trim to gain access behind the panels to lay the brake cable.

**Step 25**



Also remove the interior trim to the inside of the tailgate, as you will have to feed the cable in area.

**Step 26**



Next prepare the Y adapters for the electric's. Make a pair of these out of bullet plugs and some wire.

**Step 27**



Again test the brake light and take note of the polarity of the wire, so you know which one is + and -.

**Step 28**



Ensure the Evo spoiler are on it's new mountings. Feed the brake wire out from behind the panelling.

**Step 29**



Then feed it along to the near side end of the tailgate. Weave the brake cable along with the wiper motor wiring.

**Step 30**



Feed the wire under the tailgate trim, down the side trim and to the hinge. Bridge the gap over to the grommet and protect it as shown with a tube.

**Step 31**



Feed the wire through the grommet by the hinge and down the C pillar as much as possible. It shall exit near the small cubby hole.

**Step 32**



Feed the brake wire down to the near side rear cluster. Fit bullet plugs on the brake wire, noting the polarity (i.e. PLG for + )

**Step 33**

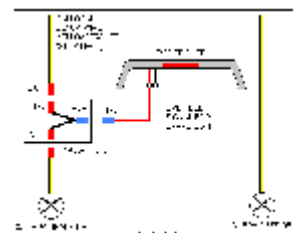

Find the live brake signal first

**Step 34**

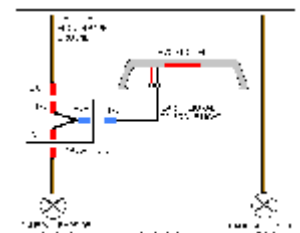

Find the earth wire next (thick brown wire). Cut the wire and fit

**Step 35**



(black wire with yellow tracer). Cut the wire and fit bullet plugs to either end and then connect the Y adapter on.

bullet plugs to either end. Connect the Y adapter to the bullet plugs and then fit the spoiler brake light wire to the Y adapters.

Now connect all the wires together and tidy up the wiring using cable ties etc.

**Step 36**



Test the wiring out buy switching on the electric's and pressing the brake pedal down. All three brake lights shall light up, and at the same intensity.

**Step 37**



With all the electric's working and everything looks tidy etc., refit the internal trim back. Then bond the spoiler on and do up the screws. The job is done :)

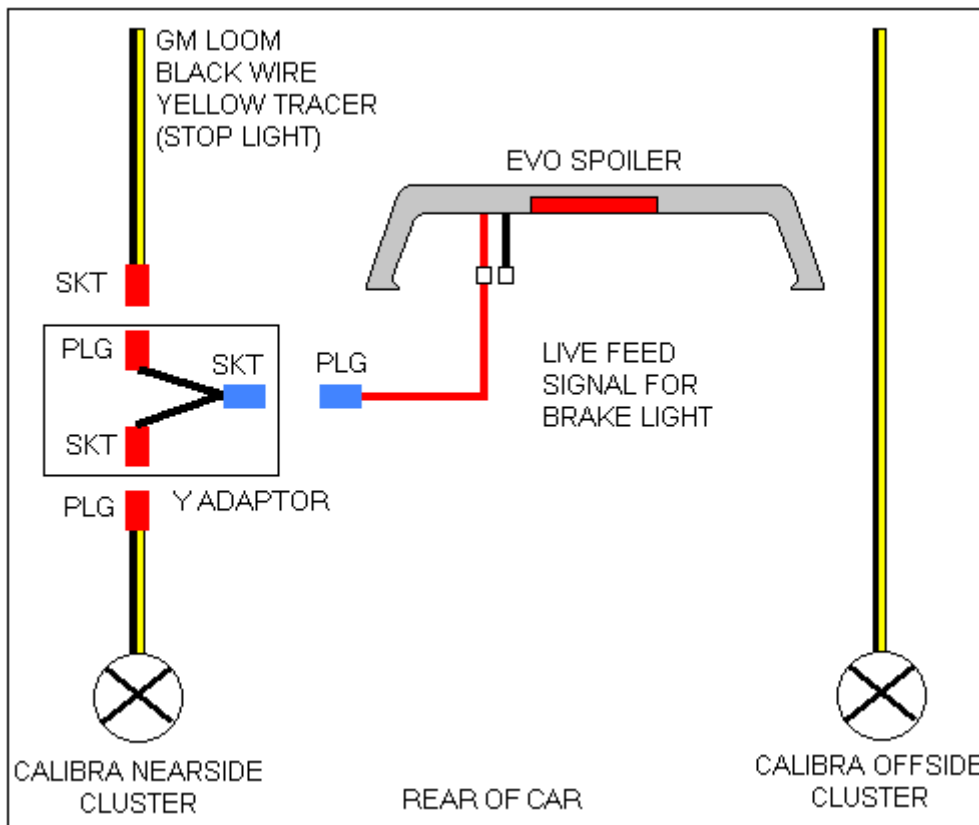

Step 33

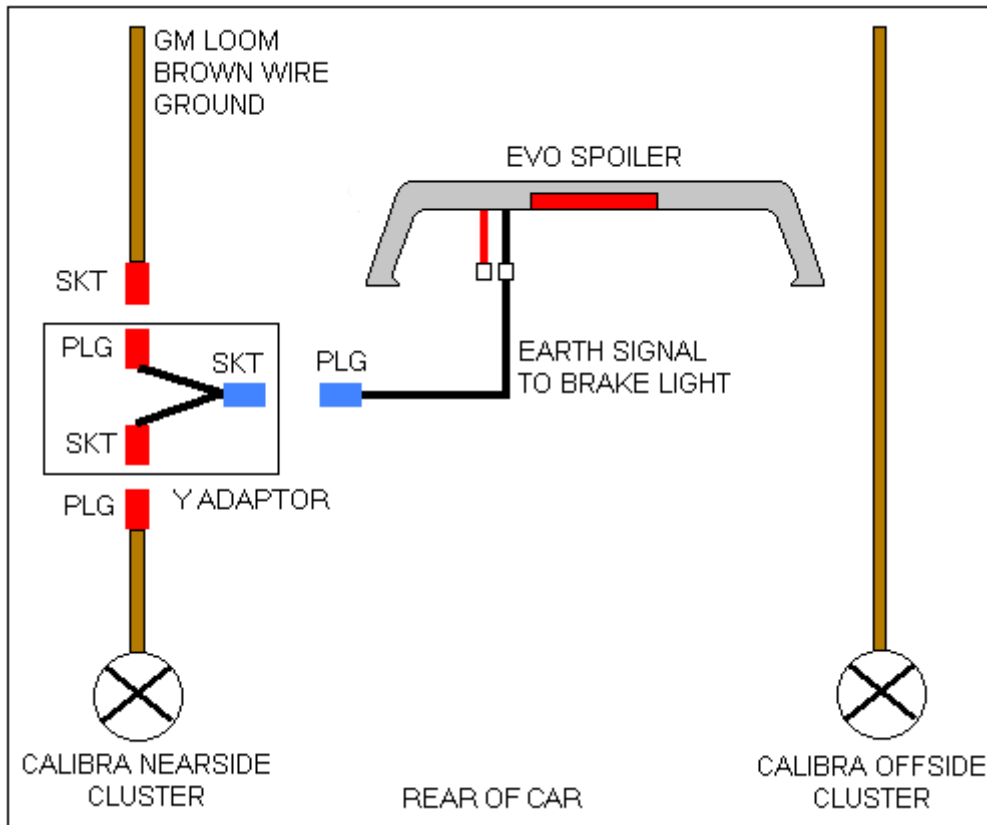

Step 34

